

4-2 Electricity – Physics

1.0 Most domestic appliances are connected to the mains electricity.

1.1 What is the frequency of mains electricity?

Tick **one** box

[1 mark]

1.05 A

50 Hz

230 V

1.2 What is the potential difference of mains electricity?

Tick **one** box

[1 mark]

1.05 A

50 Hz

230 V

1.3 Most domestic appliances are connected to the mains electricity with a plug.

Explain why a plug needs a live **and** a neutral wire.

[2 marks]

1.4 The law specifies the colour that mains wires should be for all domestic electrical circuits.

It is important that the live wire is easy to identify to reduce the risk of an electric shock.

Explain how an electric shock can be caused by a person touching the live wire.

[2 marks]

- 1.5** Most houses are supplied with mains electricity even though it is dangerous. Suggest why houses are supplied with dangerous mains electricity.

[2 marks]





- 1.6** An iron is supplied with a current of 3 A from the mains. The resistance of the iron is 100 Ω . Calculate the power of the iron.

[2 marks]

Power = _____ W

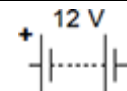
- 2.0** A student wants to investigate how the current through a filament lamp affects its resistance.
- 2.1** Use the circuit symbols in **Figure 1** to draw a circuit diagram that he could use.

Figure 1

12 V battery	variable resistor	filament lamp	voltmeter	ammeter
				

[2 marks]

- 2.2** Describe how the student could use her circuit to investigate how the current through a filament lamp affects its resistance.

[4 marks]

3.0 A student rubs a nylon comb on the sleeve of his jumper as shown in **Figure 2**

Figure 2



3.1 The jumper becomes positively charged.
How does the jumper become positively charged?

[1 mark]

Tick **one** box

Electrons move from the comb to the jumper.

Electrons move from the jumper to the comb.

Protons move from the comb to the jumper.

Protons move from the jumper to the comb.

3.2 What type of charge is left on the comb?

[1 mark]

3.3 The negatively charged comb is placed close to a charged plastic ruler. The comb and the ruler repel each other.

Which of the following is true?

Tick **one** box

[1 mark]

The ruler has the same charge as the comb.

The ruler has no overall charge.

The ruler has the opposite charge to the comb.

3.4 Electrostatic charge can damage computer chips. People working with computer chips may wear a special bracelet as shown in **Figure 3**, with a wire joining the bracelet to earth (the earth wire).

Figure 3

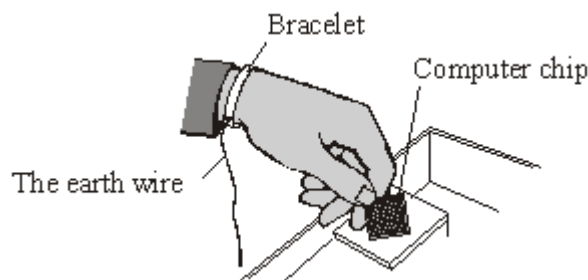

Name **one** suitable material that the bracelet could be made from.

Give a reason for your answer.

[3 marks]

Material _____

Reason _____

3.5 What name is given to rate of flow of charge through a wire?

[1 mark]

3.6 **Figure 4** shows a Van der Graaff generator. The generator contains a large metal dome that becomes charged due to friction. Electrons are carried to the metal dome causing the dome to become positively charged.

Figure 4

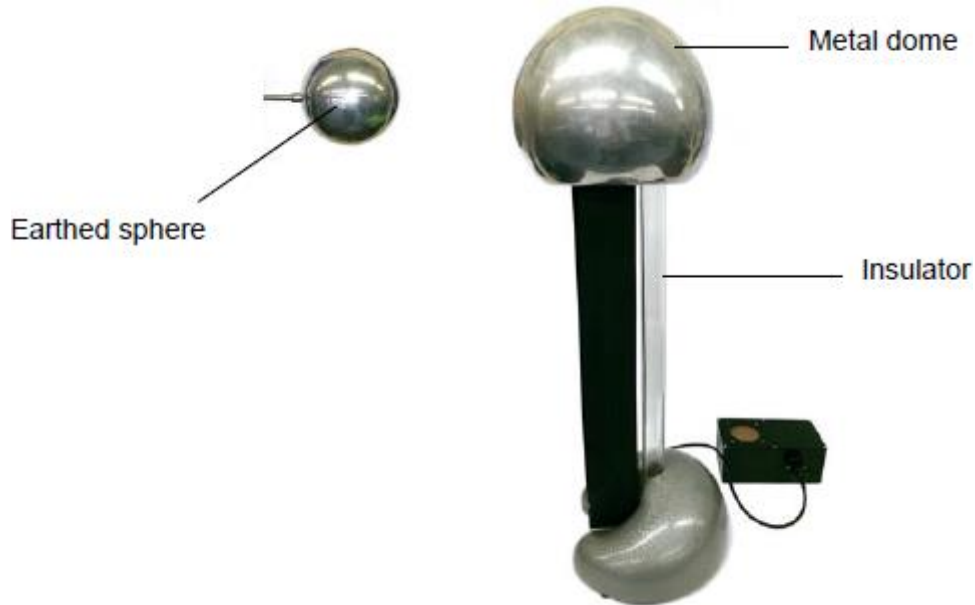

Copyright Michael Priest

The dome becomes discharged when the steel ball is brought close to it. The electrons travel to the sphere and are discharged to the Earth.

How much energy is transferred when the dome discharges?

Number of electrons transferred to the dome = 2.6×10^{13}

Charge of an electron = 1.9×10^{-19} C

Potential difference between dome and metal ball = 100 kV

energy transferred = charge x potential difference

[3 marks]

Energy = _____ J

4.0 A student sets up the electrical circuit shown in **Figure 5** below.

Figure 5

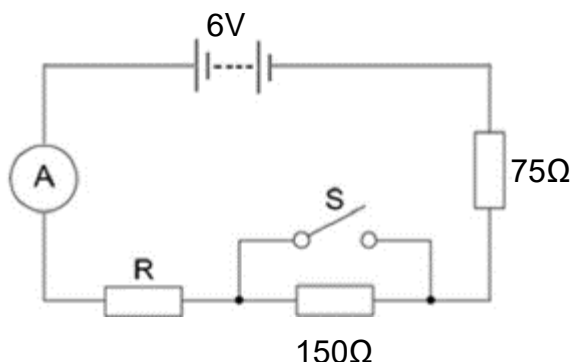

4.1 The ammeter displays a reading of 0.025 A.
Calculate the potential difference across the 75 Ω resistor.
Give your answer to 2 significant figures.

[2 marks]

Potential difference = _____ V

4.2 Calculate the resistance of the resistor labelled R.

[3 marks]

Resistance = _____ Ω

4.3 State what happens to the total resistance of the circuit and the current through the circuit when switch **S** is closed.

[2 marks]

- 5.0 A student investigated how current varies with potential difference for two different lamps of the same type. Her results are shown in the **Figure 6** below.

Figure 6

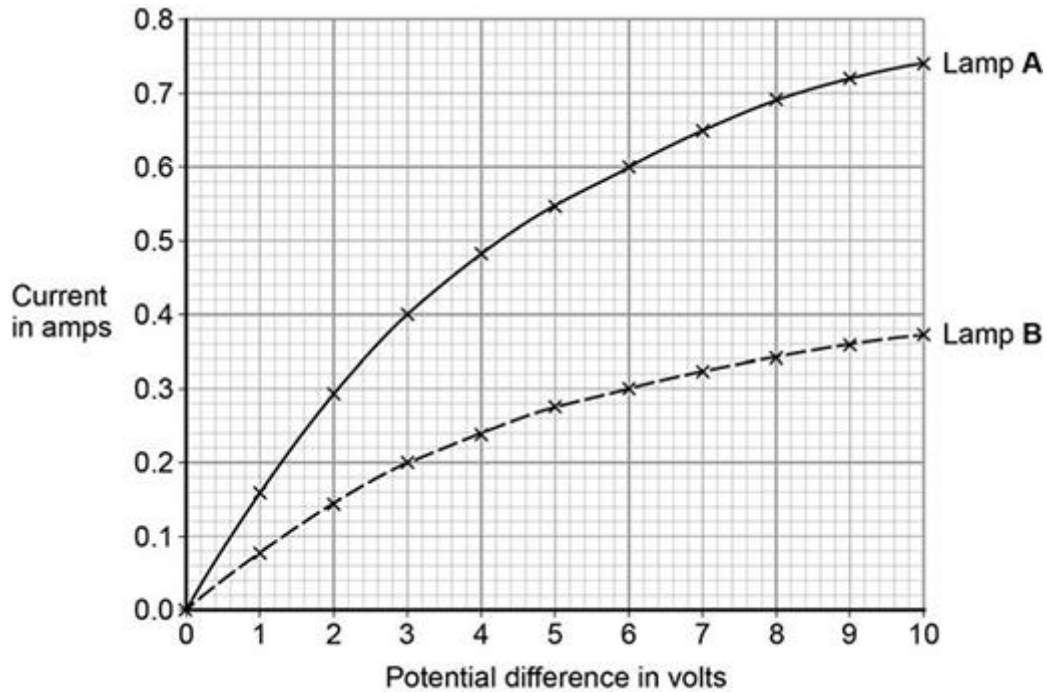

- 5.1 Draw the circuit diagram for the circuit that the student could have used to obtain the results shown in the figure above.

[3 marks]

- 5.2 The student made the following conclusion 'Lamp A is twice as bright as lamp B'. Use data from **Figure 6** to explain why the student's conclusion is correct.

[3 marks]

5.3 The resistance of each lamp increases as the current increases.

Calculate the difference between the lowest and highest values of resistance for lamp **A** from **Figure 6**.

[3 marks]

MARK SCHEME

Qu No.		Extra Information	Marks
1.1	50 Hz		1
1.2	230 V		1
1.3	Live wire carries the (alternating) potential difference/voltage (from the supply)		1
	Neutral wire completes the circuit		1
1.4	connection is made to earth	Accept answer in terms of a complete circuit or establishing a path (for charge to flow)	1
	charge can flow through the body. or large potential difference across the body		1
1.5	domestic appliances need a supply with a high power	Allow idea that houses need lots of energy allow other sensible suggestion	1
	the supply/appliance has features to reduce the risk.		1
1.6	$P = (3)^2 \times 100$	Allow one mark for $P=I^2R$ if substitution incorrect. Allow 900 (W) with no working for 2 marks	1
	900 (W)		1

Qu No.		Extra Information	Marks
2.1	battery, lamp and ammeter connected in series with variable resistor		1
	voltmeter in parallel with (filament) lamp		1
2.2			
Level 2:	A detailed and coherent description of the experiment. The response provides a logical sequence.		3-4
Level 1	: Simple description of the experiment with some steps missing. The response may not be in a logical sequence and may not lead to the collection of valid results.		1-2
Level 0:	No relevant content		0
Indicative content			
ammeter used to measure current voltmeter used to measure potential difference resistance of variable resistor altered to change current in circuit or change potential difference (across filament lamp) resistance (of filament lamp) calculated or $R=V / I$ statement resistance calculated for a large enough range of different currents that would allow a valid conclusion about the relationship to be made			

Qu No.		Extra Information	Marks
3.1	Electrons move from the jumper to the comb.		1
3.2	negative		1
3.3	The ruler has the same charge as the comb.		1
3.4	copper it is a metal allows charge to flow	allow any named metal	1
			1
		allow is an electrical conductor	1
3.5	Current		1
3.6	0.494 J	Allow 0.5 J or 0.49 J	1
		Total charge = N electrons x charge per electron $2.6 \times 10^{13} \times 1.9 \times 10^{-19} \text{ C} = 4.94 \times 10^{-6} \text{ C}$	1
		Total charge (C) x pd (V) = energy (J)	
		$4.94 \times 10^{-6} \times 1 \times 10^5 = 0.494 \text{ J}$	1

Qu No.		Extra Information	Marks
4.1	$V = 0.025 \times 75$ 1.9 (V)		1
		Allow 1.9 (V) with no working for 2 marks	1
4.2	total resistance = $6 / 0.025$ $R = 240 - 225$ 15 (Ω)		1
			1
			1
4.3	resistance decreases current increases		1
			1

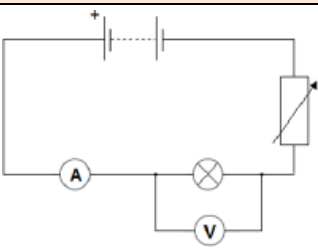
Qu No.		Extra Information	Marks
5.1		<p>battery in series with bulb and ammeter</p> <p>voltmeter in parallel with the bulb</p> <p>variable resistor or variable power supply</p>	<p>1</p> <p>1</p> <p>1</p>
5.2	<p>correct pair of current readings at the same pd</p> <p>therefore</p> <p>current in lamp A is twice the current in lamp B</p> <p>so</p> <p>lamp A is twice as powerful and lamp B (hence is twice as bright)</p>	<p>eg at 10 V, $I_A = 0.74A$ and $I_B = 0.37A$</p> <p>must refer to power/ rate of energy transfer</p>	<p>1</p> <p>1</p> <p>1</p>
5.3	<p>$R = V / I$</p> <p><u>Lowest</u></p> <p>$R = 0.6 / 0.1$</p> <p>$R = 6 \Omega$</p> <p><u>Highest</u></p> <p>$R = 10 / 0.74$</p> <p>$R = 13.5 \Omega$</p> <p>Difference = $13.5 - 6 = 7.5 \Omega$</p>	<p>allow $R = 1.0 / 0.16$</p> <p>$R = 6.25 \Omega$</p> <p>(other values may be acceptable but the values from the graph must be when $V \leq 1V$ and the lamp can reasonably be assumed to be ohmic)</p> <p>allow 7.25Ω if consistent</p>	<p>1</p> <p>1</p> <p>1</p>